

István Balajti

Overview of the International Radar Symposium Best Papers, 2019, Ulm, Germany

Nowadays, the interference cancellation or mitigation plays a key important role in the effective use of the advanced radar technology. This article is focused on the symposium presentations related to Electromagnetic Spectrum Operations (EMSO) of the radar systems. The modernisation of the Hungarian Army, the success of the Zrínyi 2026 program, basically depends on the understanding and the professional service of new technologies during their lifecycle. In civilian applications, the inter-radar interference of automotive radars is an emerging problem for automotive radar applications in case of dense deployment. Consequently, it is a priority task to gather, evaluate and transfer collected expertise on the advanced research findings and concepts related to emerging sensor technologies. It looks like the permanent engineering/scientific policies should be implemented to monitor and maximise radar performance to support safety measures required within EMSO. The article summarises the most recent results of the radars taking into account the domestic expectations.

Keywords: radar, electronic attack/electronic protection, Passive Radar (PR), Bi- & Multistatic Radar Systems, Cognitive Radar

Introduction

The Germany based International Radar Symposium (IRS) has a long historical development and celebrated its 20th anniversary at the end of June 2019 [1]. The successful start was in Munich, Germany, in 1998, where the author of this article represented the Hungarian Institute of Military Technology with a paper. In 2019, the IRS was held in the city of Ulm in cooperation with the Fraunhofer Institute for High Frequency Physics and Radar Techniques FHR and Hensoldt Holding GmbH. Figure 1 shows the time and location of the IRS conferences.

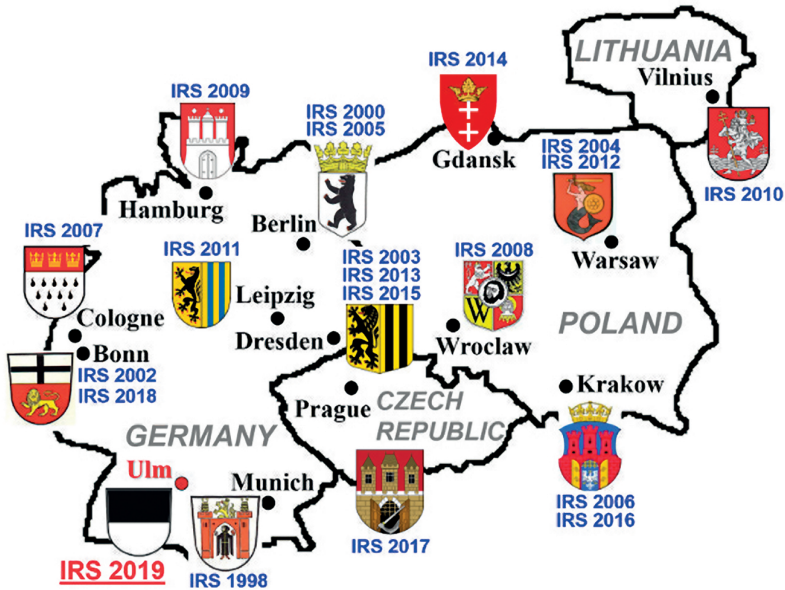

Figure 1.
Map of International Radar Symposium (IRS) locations [2]

The invitation of Professor Peter Knott pointed out the fact that: "The International Radar Symposium aims to provide a forum for both academic and industrial professionals in radar from all over the world and to bring together academicians, researchers, engineers, system analysts, graduate and undergraduate students with government and non-government organizations to share and discuss both theoretical and practical knowledge" [1].

The keynote speakers were:

- R. Bil: *Radar Technology – Past, Present, Future*. Hensoldt Sensors GmbH, Germany. The key message of the speech was that: "Future radar systems featuring broadband capabilities are one of the most important requirements. They will rely on AESA antennas with their inertia-free beam steering and flexible scanning capabilities, their ability to adaptively set antenna patterns and their high reliability. The multifunctional RF-systems offering major operational advantages, even more so if they end up as Digital Software Defined Systems."
- M. Suess: *Current and Future Space Based Radar Missions and Systems of European Space Agency*. ESA, Germany. The presentation provided an overview of the Earth Observation programme developed by ESA.
- M. Eggers: *Military Radar Lifecycle Support*. NATO Support and Procurement Agency, Luxembourg. The presentation pointed out the fact that the Life Cycle of military Air Surveillance radar systems typically extends over 30 years. A sound approach to Life Cycle Management in the concept, procurement and in-service phase is fundamental to ensure operational availability, affordability and adaptability to evolving technology and capability requirements.

The author's findings in this article are subjective and focused on the main topics; those that might be of interest for the Hungarian readers are highlighted in italics:

- Radar, *Artificial Intelligence and Machine Learning*
- *Cognitive Radar/Recognition*
- *PCL Passive Radar: Fundamentals, Challenges, Future*
- Passive Radar Imaging
- Passive and Multi-Static Radar
- *Automotive Radar*
- *Drones*
- Polarimetric and Weather Radar
- Radar Propagation and Simulation
- *SAR and ISAR Techniques and Applications*
- Multi-Channel Digital Radar and SAR Systems
- *THz Sensing*
- *UWB and Noise Radar*
- *Low-Frequency/OTH Radar*
- *Radar Systems and Components*
- MIMO Radar/Beamforming
- Signal Processing
- Detection/Estimation
- Forward Scattering Radar
- Positioning, Direction Finding and Tracking

Technical Matters of the Conference

Here follows an overview of presentations which are within our interest on the Symposium. Please note: Electromagnetic Spectrum Operations (EMSO) is the planning, coordination and management of the joint use of the electromagnetic spectrum: from 1 MHz to 1 THz; Infrared; and Optical.

Findings on passive radar systems

The host Hensoldt Co. and the Fraunhofer FHR Institute were the most active in the introduction of new findings. M. Weiß presented the paper on *Aspects of Next Generation Sensor/Radar Networks* [3]. Figure 2 shows the topology of the centrally controlled two-way synchronisation principle. Normally, this synchronisation is carried out separately at each node by using a module linked to a stable local oscillator (STALO). This STALO can be disciplined to another time/frequency source to establish a synchronous network. However, as there is no feedback to the master node about the status of the synchronisation, *this approach can easily be jammed or interfered*. The proposed approach is to overcome this situation. This radar network consisting of distributed nodes which communicate via a highly efficient flexible communication network is described. It continuously monitors and adapts to changes in the time transfer quality and node-to-node baselines to maintain the *best possible coherence* at the time. In

the tight synchronisation between the nodes of the network in the sub-nanosecond range new signal processing approaches can be implemented enabling a distributed coherent range/ Doppler processing to extract more target parameters and characteristics for an improved target classification.

The detection performance and estimation accuracy of position and speed (Doppler) is improved and able to cope with an increased number of targets. The backbone for a distributed cognitive sensor/radar network is the communication and data flow among the nodes.

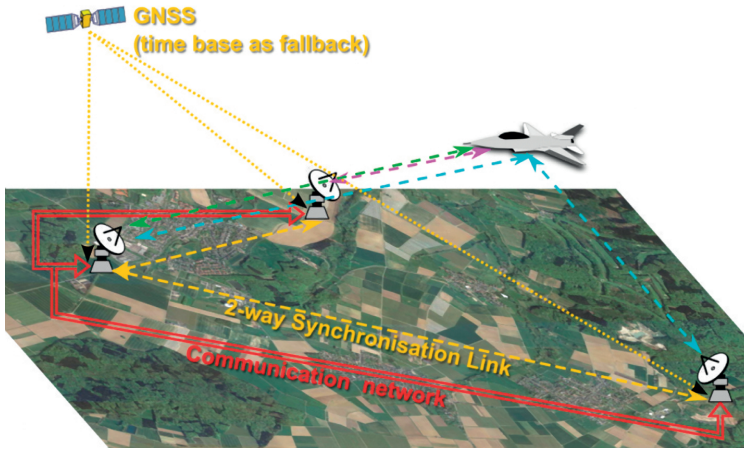

Figure 2.
Topology of a distributed cognitive sensor/radar network [3]

Deep Learning techniques from the Big Data Analytic area employed during the data fusion stage allows to create a cognitive radar network as shown in Figure 3. After transferring the data to a central node, the fusion engine will be fed by feature extracted information gained from the pre-processing stages.

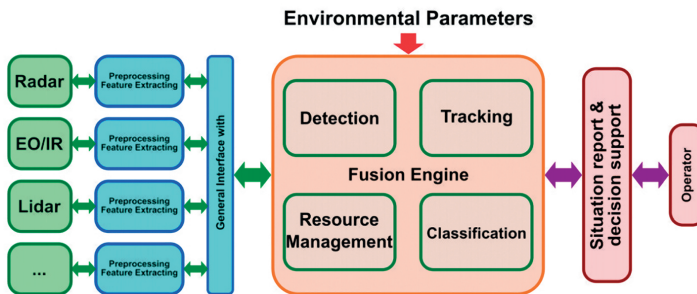

Figure 3.
The data and fusion architecture of the sensor network [3]

A comprehensive paper was presented by V. Winkler and S. Lutz on *Large-Scale Passive Radar Cluster Operation* [4]. Hensoldt Co. has conducted a measurement campaign with four PR

stations. Figure 4 shows the PR stations for different broadcasting signals. The single sensors themselves have been enhanced with new receivers, software modes like DVB-T2 and network interface for exchanging target data, monitoring and control. The contribution and properties of the single sensor types can be presented next to the achievable coverage and accuracy of the global sensor fusion. Figure 5 displays Constellation Diagrams and Parameter for DAB, DVB-T and DVB-T2 coherent signal processing. Synchronisation in time for DVB-T can be performed by correlation with the pilot pattern over four symbols, which is the repetition interval of the scattered pilot pattern.

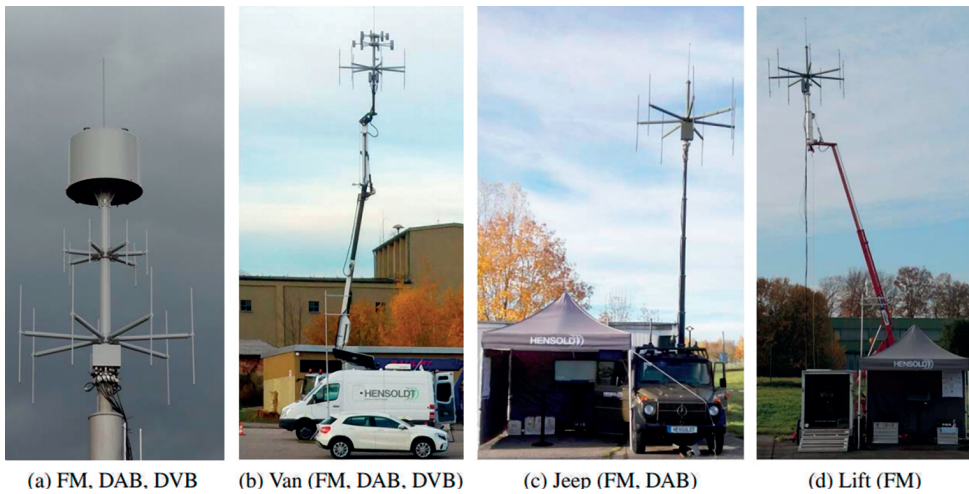

Figure 4.
Stationer and mobile PRs for Large-Scale Cluster Operation [4]

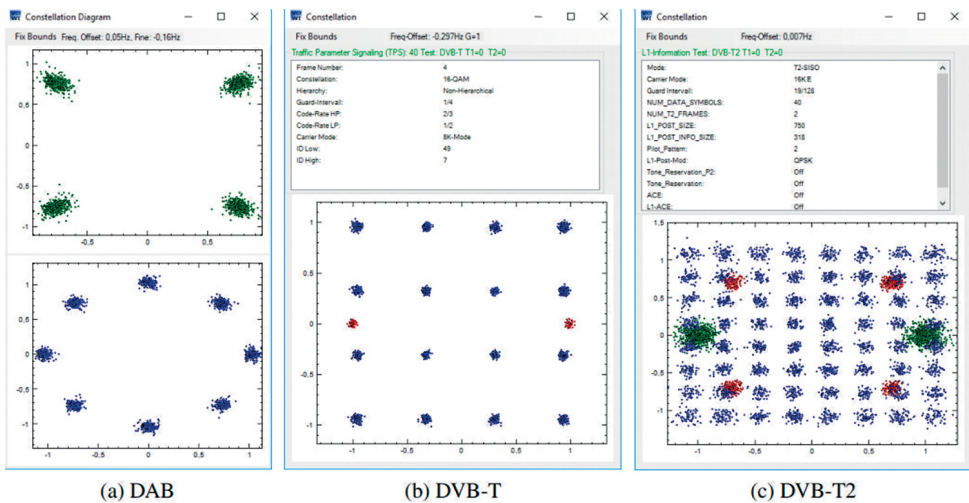

Figure 5.
Constellation Diagrams and Parameter [4]

The experimental cluster operation has shown the scalability of the network and the possible performance gain due to sensor fusion.

The paper of K. Kulpa and M. Malanowski *From Klein Heidelberg to Modern Multistatic Passive Radar* presents the history of the PR, and the present stage of the development of the abovementioned technology in military and civilian applications [5]. Today, a typical application of PR is the detection and tracking of airborne targets, such as airliners or short-range surveillance, for example drone detection in the vicinity of an airport. Among many promising PR prototypes, one is the PET-PCL system, Figure 6, developed by the Polish company PIT-RADWAR, in cooperation with the Warsaw University of Technology and AM Technologies. A single node of the system is able to detect targets using FM, GSM and DVB-T transmitters as illuminators of opportunity, and can also track targets using a Passive Emitter Tracking (PET) subsystem using DOA and TDOA technology. The conclusion of the paper is that PR can be used effectively for micro-Doppler analyses and non-cooperative target recognition in military operations. This technology is not going to replace active radars; still, it is a good technology for gap-filling and for supporting classical radar sensors and extending their capabilities.



Figure 6.
PIT-RADWAR's PET-PCL prototype radar [5]

The presentation of F. Santi, F. Pieralice, D. Pastina, M. Antoniou and M. Cherniakov *Passive radar imagery of ship targets by using navigation satellites transmitters of opportunity* draws attention to the advanced capabilities to the GNSS-based radar for maritime surveillance applications [6]. Figure 7 shows the experimental campaign geometry. The measurement results obtained with Galileo satellites demonstrate the effective possibility of the proposed approach to extract relevant features of ship targets of interest. A passive imaging mode has been defined to form bistatic ISAR images of the detected ship.

Real data analysis, involving a large ferry reflecting the signals transmitted by two Galileo satellites, confirmed the effectiveness of the defined processing scheme along with a proper mathematical framework aiming at evaluating the length of the detected vessels directly from the focused images.

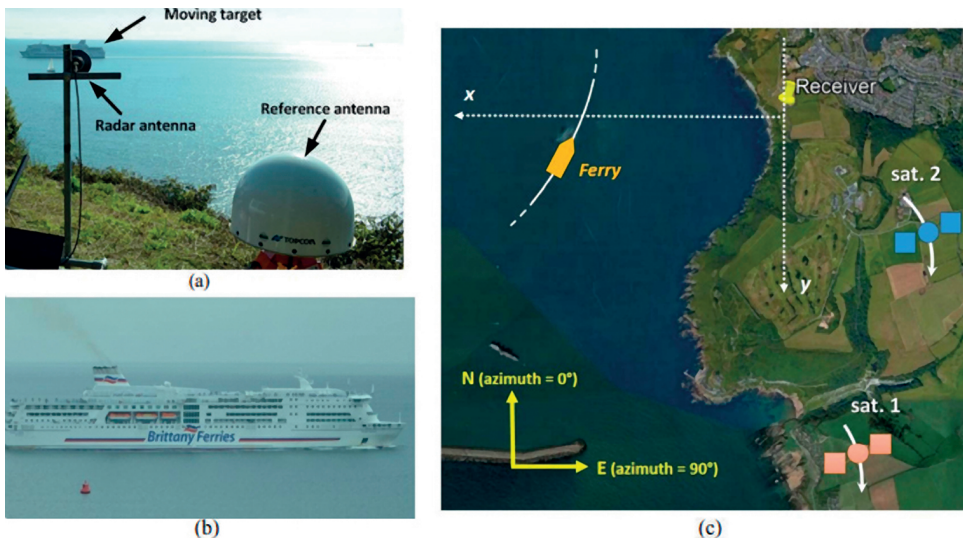

Figure 7.

Experimental campaign: (a) Experimental hardware (b) Target of opportunity (c) Acquisition geometry [6]

Findings on drone-related systems

The paper of I. Norheim-Næss, E. Finden and K. Strøm *Passive Radar detection of small UAV over sea* summarises the findings of the trial over the Trondheim-fjord in Norway (autumn 2018), where a DVB-T based passive radar system was used for detecting a small unmanned aerial vehicle (UAV) [7]. Figure 8 shows where the UAV has been visible out to approximately 600 m bistatic range, with Doppler at +18 Hz at cruise speed outbounds, and more than -40 Hz full speed inbound. The strong multipath from the sea, with a single receiver channel, severely affect the radar performance, which could shorten detection distances. It could be mitigated by using two to three receiver channels at differing altitude, with the benefit of an additional gain of up to 6dB caused by the multipath.

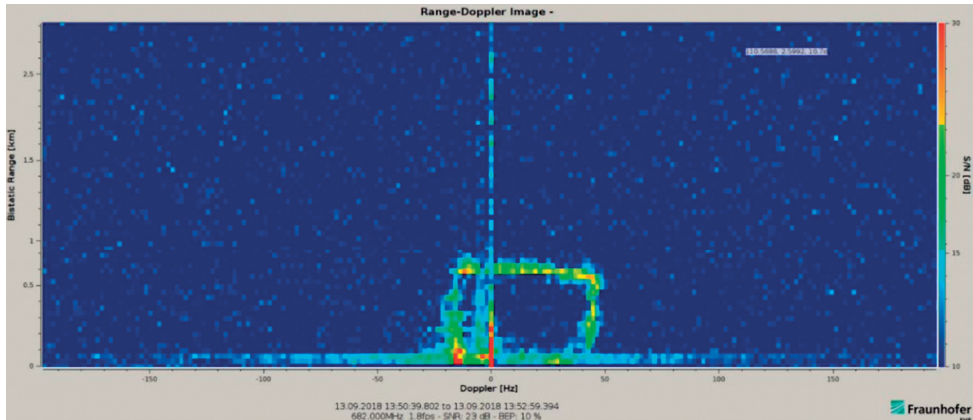

Figure 8.

Drone detection: Horizontal axis-Doppler in Hz, Vertical axis is bistatic range [7]

The paper on *Drone-features and their corresponding consequences for the design of a radar for drone-detection, tracking and classification* by A. Strecker covers the main radar performance defining events such as the micro drone features and corresponding radar requirements [8]. Hensoldt Co. sensors characterise different kinds of micro drones, for which the requirements of the radar's physical features are analysed. The conclusion is that the detection of small/micro drones with RCS of 0.01 m² or blades with 0.001 m² and flight dynamics is possible with PR, which has the following radar characteristics:

- High inherent system stability or sub clutter visibility of > 50dB
- Operation in urban area > 60dB/70dB due to reflections of houses, fences, masts
- Very low system antenna sidelobes in azimuth > 40dB for good decoupling between other targets like traffic with higher RCS than the small drone
- Doppler high resolution, better than 0.5m/s (1.8km/h) for drone and clutter separation
- High update rate < 2s due to possible flight dynamic behaviour of drones
- Generation of 3D information of the drone for automatic master slave operation with an optical system

The following paper by F. X. Hofe *A New Algorithm for Automatic Radar Target Classification* applies feature extraction with special regard to drones, recognition of target-typical characteristics and features of the spectrum and of the cepstrum, derived from the time-signal [9]. The number of features can be steadily expanded for each of these target types, but also for other types of target (air targets such as gliders, airplanes and jet, as well as missiles and water targets such as swimmers, rowboats and motorboats). Thereby the reliability of the algorithm is successively increased further by having more and more features. Figure 9 shows only plots on the left, while the right part shows only tracks with bird- (in blue), drone- (in yellow) and "unknown"- (in white) classification.

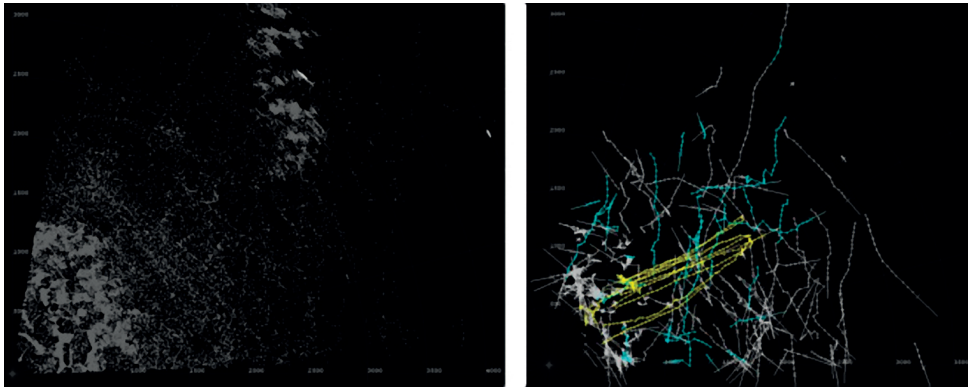

Figure 9.
Operational results: Only plots (left), only classified tracks pictured (right) [9]

The combination of the present method with classification models and their learning and training styles (techniques such as Classification Tree Method, K-Nearest-Neighbors Algorithm, Support Vector Machine, Ensemble Learning and Discriminant Analysis, etc.) further increase the reliability of the method. The method is further stabilised in the subsequent tracking and compared with the kinematics of the target. This further increases the probability of a correct classification.

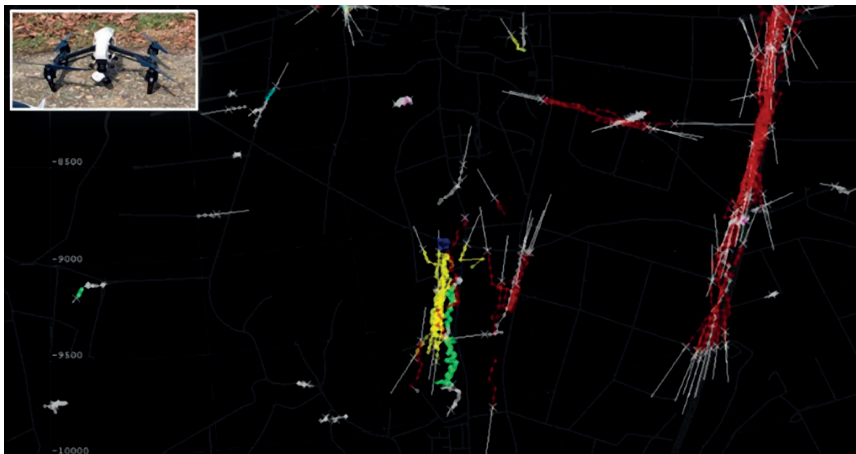

Figure 10.
Operational results: UAV and pedestrian classified in 9.5 km [10]

The next paper *Architecture and Operational Results of Feature Based Automatic Radar Target Classification* by A. Hanewinkel concludes the Hensoldt Co. drone detection related topics [10]. The article compares the advantages and shortcomings of FMCW and PULSE-Doppler technologies. The FMCW radar technology with their physical limit of sub-clutter-visibility, caused by mostly cheaper reference oscillators transmitting and receiving at the same time,

is increasing the noise and threshold in the upper Doppler bins. The pulse-Doppler variant benefits from the high decoupling between transmit and receive pulse, decoupling in angle by using multiple pencil beams and an extreme small phase noise level, creating a good sub-clutter-visibility. Figure 10 depicts the fact that the radar was able to classify without any third-party information a drone in 9.5 km by detecting the rotor blades.

The probability of correct spectral classification reduces the load of the operator on system level, and can give an adequate preselection for any effector. The algorithm itself is achieving a probability of correct classification $> 90\%$. This was verified with different scenarios as urban, forest, heterogeneous ground scenarios and was tested at different weather conditions (wind, rain, snow, etc.) as well. With the given architecture, the classifier can be easily expanded with new drone types and therefore spectra, as the market is still growing dramatically.

M. ScharTEL gave a talk on *Ground Penetrating Synthetic Aperture Radar (GPSAR)* that can be operated on an autonomous flying drone [11]. The SAR imaging results using a real time kinematic global navigation satellite system (RTK GNSS) and a total station for position acquisition are compared. Figure 11 shows the test system consisting of an RTK base station, a total station, and the drone. The drone is equipped with an RTK GNSS rover station, a 360° -prism, a single-board computer for data storage, and the bistatic FMCW SAR.

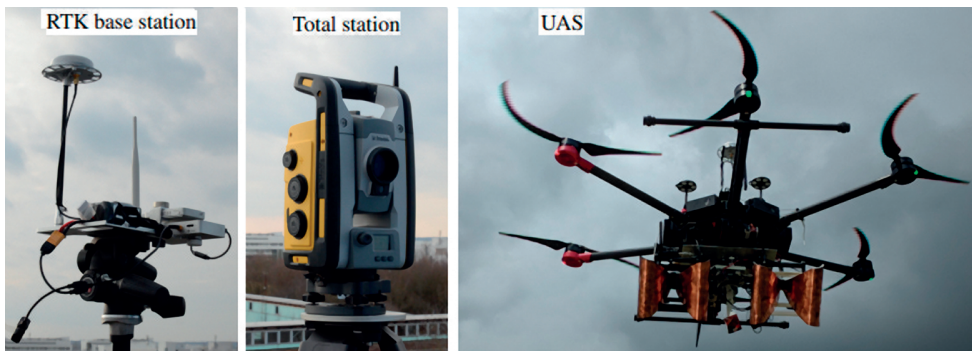

Figure 11.
The proposed system components [11]



Figure 12.
Photo of the measurement setup [11]

The systems are compared on the basis of the quality of SAR images using a simple test scenario shown in Figure 12 and realistic trajectories as shown in Figure 13.

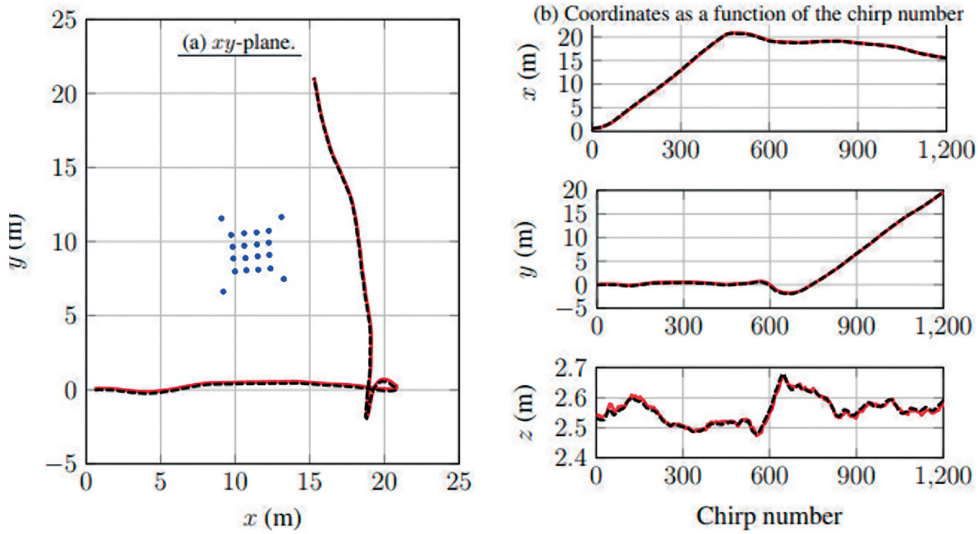

Figure 13.

Trajectory of the multicopter (L-shaped flight) measured with the RTK GNSS (—) and the total station (---). The positions of the reflectors are marked with (*) [11]

After compensation the distance-dependent signal attenuation, the 12 single-look SAR images are combined by an incoherent addition as shown in Figure 14. The measurement result shows, that the total station solution outperforms the RTK GNSS solution in terms of signal-to-noise ratio by 10dB. The degraded image quality can be explained by the lower position accuracy of the RTK GNSS and mainly by time synchronisation errors.

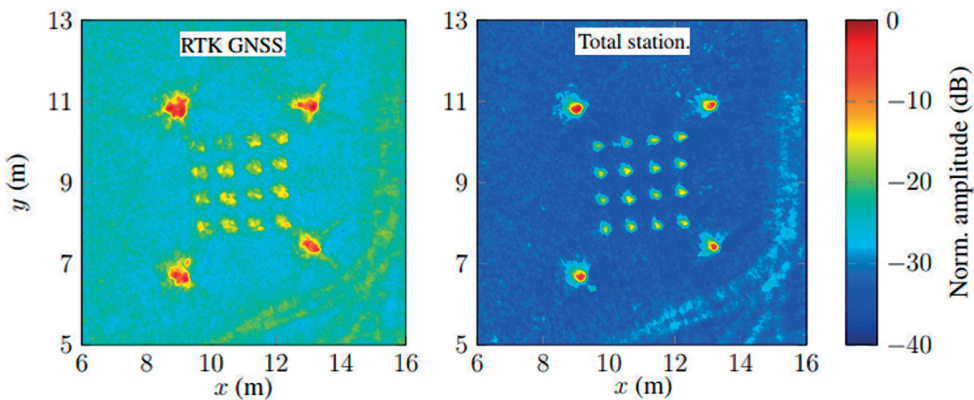

Figure 14.

Measurement setup and test trajectories [11]

C. Wasserzier, J. G. Worms, D. O'Hagan described a prototype system and experimental assessments of the measurement precision of *A Concept for Far Field Measurements of Large Dimension Antennas in an Open Area Test Site Performed by UAS* [12]. This paper introduces different applications of UAS in the broader context of the realisation of an open area test site such as Figure 15 and Figure 16 depict. Figure 15 shows that the drone flies around the antenna in different heights in order to achieve full beam patterns of distinct height sections.

The performed experiment proved a power link measurement with an error of 0.1dB which is proof of the presented concept. In general, the better the GPS accuracy is the more accurate is the measured power budget. Practical assessments underline the flexibility of a UAS based measurement setup, but also show the limitations in measurement accuracy.

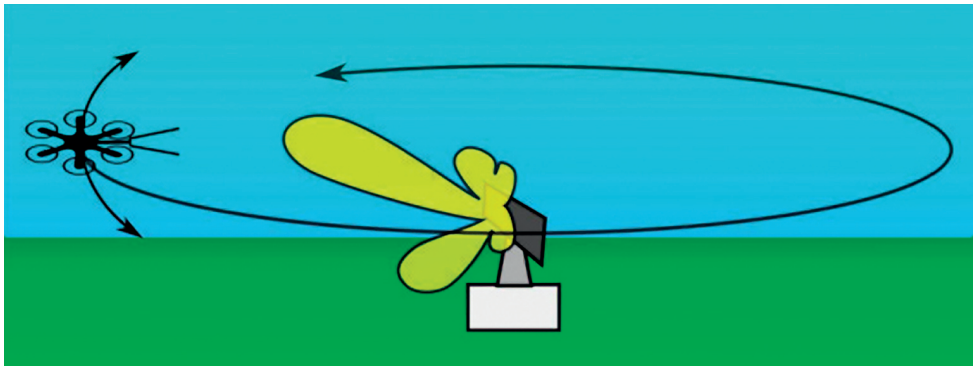

Figure 15.
UAV measuring the beam pattern of an electronic scanning antenna [12]

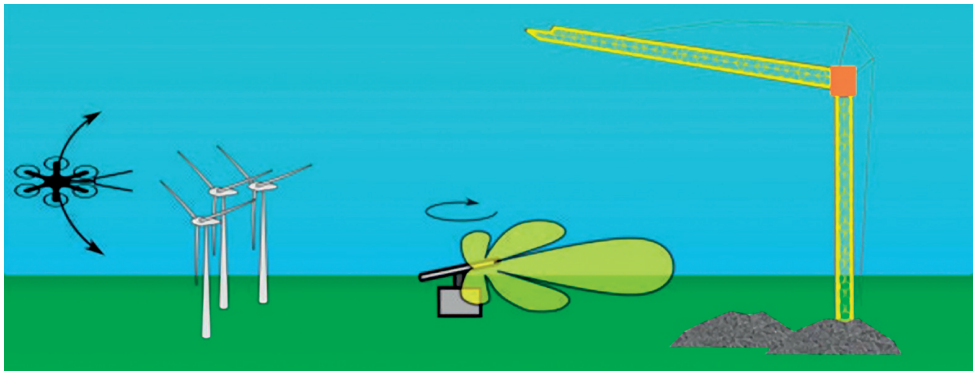

Figure 16.
Determining the influence of permanent and temporary obstacles [12]

The feasibility and the benefits of a *Radio Frequency Sensor payload for Remotely Piloted Aerial Systems (RPAS) based on the Scalable Multi-Function RF System (SMRF)* concept has been demonstrated [13]. The European Defence Agency is aiming at developing an architecture for SMRF systems applying modularity, standardisation and Commercial Off-The-Shelf (COTS)

technologies to achieve flexibility in size, performance and functionality. The SMRF is the next generation of RF sensors that support simultaneous operation of several RF functions like Radar, Electronic Warfare (EW) and communication links. The objectives of this project were to analyse and assess the benefits of the employment of SMRF – as an example for a possible platform – in the field of a Medium Altitude Long Endurance (MALE) Remotely Piloted Aerial System (RPAS) and to gather the requirements for building a demonstrator for showcasing those benefits in a real environment. The RPAS has to provide the following different RF capabilities, as visualised in Figure 17.

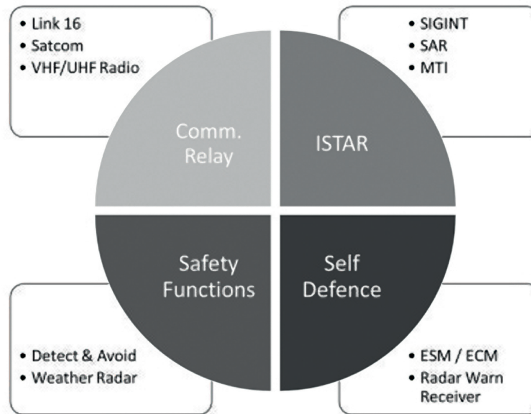

Figure 17. Functional areas to be covered by a SMRF sensor system [13]

There are three functional domains of the RF system operation, which can be distinguished, with respect to the corresponding RF modes such as Mission-related, Self-Defence (ECM) and Safety-related, as listed in Table 1.

Table 1. RF modes in different functional domains of a RPAS [13]

Mission-related	Self-Defence (ECM)	Safety-related
Synthetic Aperture Radar (SAR)	Stand-In Jamming	Sense and Avoid (S&A)
Spotlight-SAR (Spot SAR)	Deceptive Jamming	
Inverse SAR (ISAR)	Escort Jamming	Identification, Friend or Foe (IFF)
Moving Target Indication (MTI)	Cross-Eye Jamming	
Space Time Adaptive Processing (STAP)	Cross-Pol Jamming	
Real Beam Ground Mapping (RBGM)	Early Warning Receiver	Weather radar
Automatic Target Recognition (ATR)		
High Range Resolution (HRR)		
Electronic Counter Measures (ECM)		
Electronic and Communication Intelligence (ELINT and COMINT)		
Communication Relay		

The physical realisation of the demonstrator is envisaged to consist of a single face low-band AESA array; a single face high-band AESA array; an omnidirectional antenna; a single RF special application (self-defence) unit; and a high-performance processing unit.

Based on the technology tracks, a very rough order of magnitude (VROM) budget estimate has been made for the realisation of the SMRF demonstrator, including integration and testing on a relevant flying test bed.

M. Jahangir and C. J. Baker introduced *drone test flight results for non-cooperative surveillance using an L-band 3-D staring radar* [14]. The huge concern for the safe and secure operations of drones in the presence of manned aviation is an issue of major public interest. The Sky ATM Research (SESAR) Joint Undertaking programme is pursuing a range of projects that aim to develop the capability to enable complex drone operations with a high degree of automation. Aspects specific to Unmanned Traffic Management System (UTMS) that relate to ground-based technologies for a real-time unmanned aerial system traffic management system (UTMS) are being addressed within the CLASS (CLear Air Situation for uaS) project. Figure 18 summarises the CLASS system architecture used for real-time UTM.



Figure 18. CLASS system architecture used for real-time UTM [14]

The set of Key Performance Indicators (KPI) defined to quantify the tracking aspect of the system such as Probability of Update (PU) is a value expressed in %, which is the ratio between true positive drone detections from tracker to total drone detections from reference, Mean Gap per track, False Positive Rate, Horizontal Position Error and Vertical Position Error. The proposed KPIs are open to discussion and alternative metrics like Single Integrated Air Picture (SIAP) may provide a more common basis for performance benchmarking. Machine learning on kinematic and Doppler features demonstrated a good illustration of discrimination between drone and non-drone categories. There is work in progress aiming at the expansion

of machine learning and testing it this against a wider set of operationally realist scenarios as depicted in Figure 19.

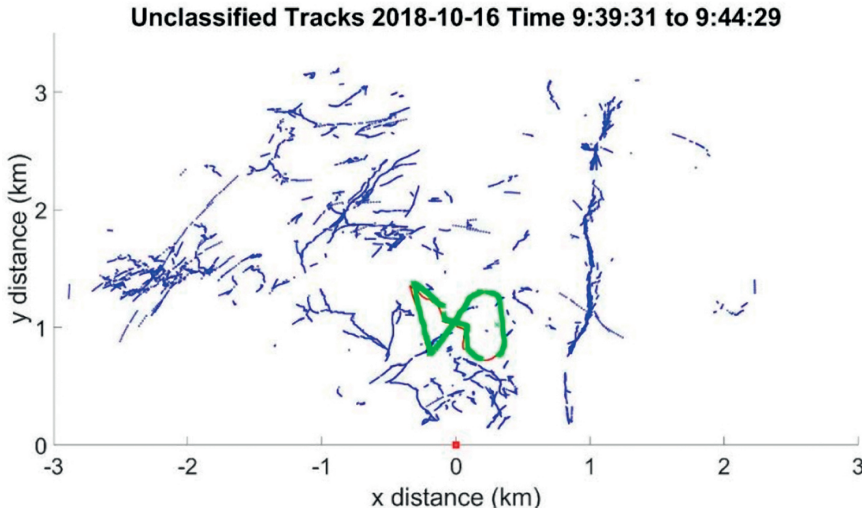

Figure 19.

Gamekeeper radar tracks prior to classification for scenario Urban Pollution Sampling with DJI Inspire drone GPS truth is shown in red, radar tracks in blue and the one that matches the GPS truth is highlighted in green [14]

Findings on emerging technologies

The Italian authors introduce findings on the *target detection and localization capabilities of a coherent multiple input multiple output (MIMO) radar network* designed and implemented using *photonic technology* [15]. The benefit offered by photonics is twofold: it guarantees long-time phase stability and frequency/phase coherence between the transmitted and received radio frequency signals; secondly, it allows remoting the antennas by exploiting optical fibres.

The architecture of the Photonic Radar Network consists of a photonic core, a collocated acquisition system, and two radar heads (RHs) with one TX and one RX each, that can be opportunely remoted by means of optical fibres, as depicted in Figure 20. Note: DSP: Digital Signal Processing; ADC: Analog-to-Digital Converter; RF: Radio Frequency; LPF: Low-Pass Filter; E/O: Electro-Optical; OD: Optical Delay Line; O/E: Opto-Electrical; IF/BB: Intermediate Frequency/Base Band; BPF: Band-Pass Filter.

Figure 21 shows the geometry of the coherent photonics-based MIMO radar network and in-field experimental setup. The experiment is realised with a scaled-down geometry. However, the presence of a long spool of fibre (the OD in Figure 20) simulates a distance of about 1 km between the two RHs. In the following, the results will demonstrate the low attenuation and negligible phase distortion introduced by the fibre. Moreover, we can consider the network being characterised by widely distributed antennas, since the four channels are spatially de-correlated. Measurement results are depicted in Figure 22 (left) and 22 (right), respectively.

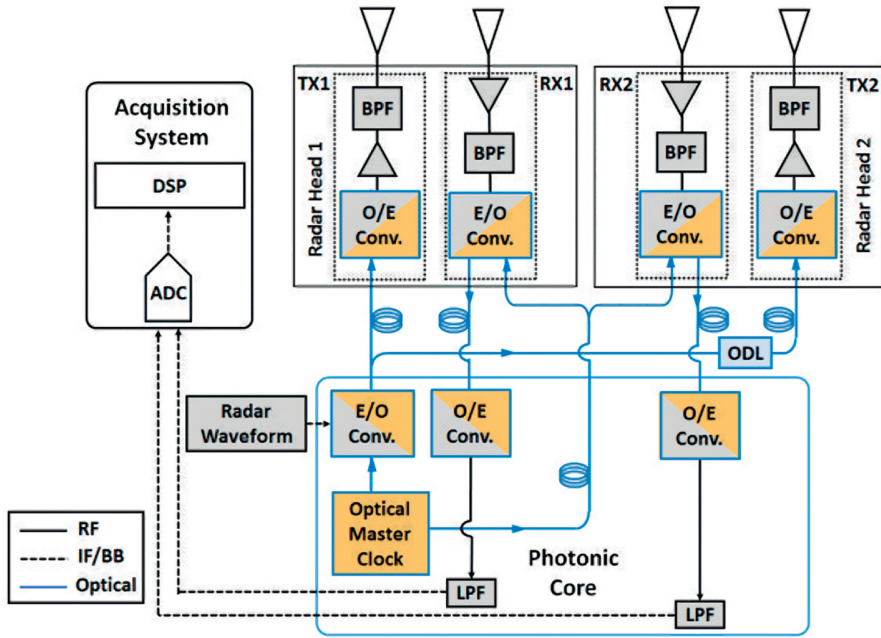

Figure 20. Architecture of the Photonic Radar Network [15]

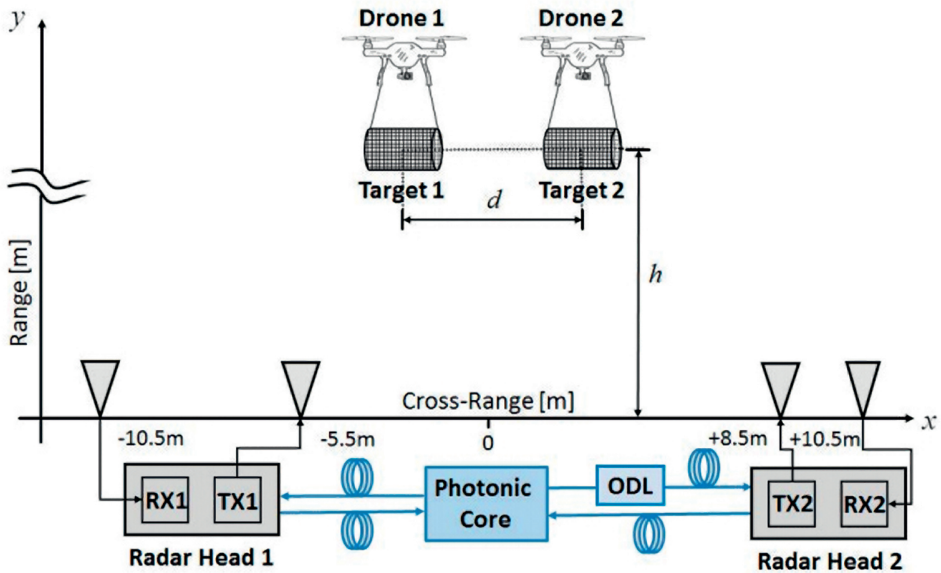

Figure 21. Geometry of the coherent photonics-based MIMO radar [15]

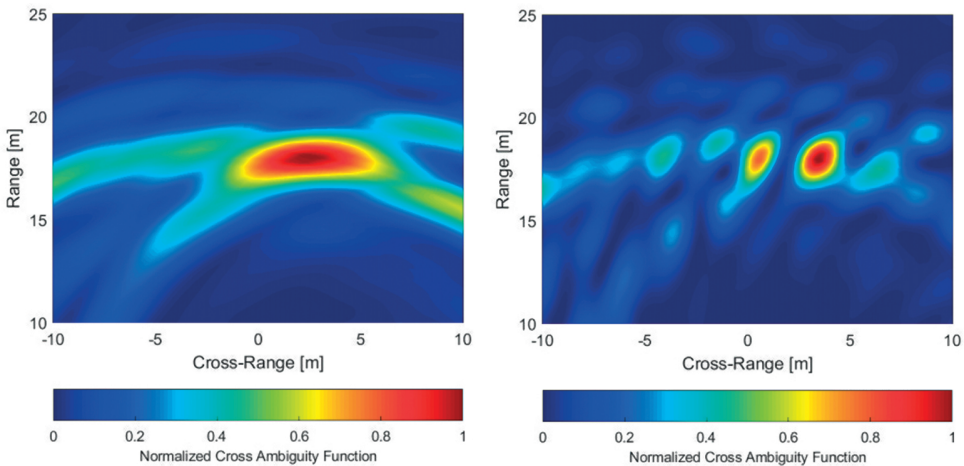

Figure 22.

Non-coherent (left) vs. coherent MIMO images in the multi-target scenario [15]

The results obtained confirm that photonics is an effective technology for coherent MIMO radars with widely distributed antennas. It has capability to preserve signal coherence among the TX and RX elements, while it grants large bandwidth long-range undistorted signal distribution over fibre.

Intradoses measurement results of the research in *Simultaneous Transmit and Receive (STAR) systems self-interference cancellation* support the usage of the radar and communication systems with higher spectral efficiency [16]. Conventional systems operate in a half-duplex mode, either transmitting and receiving at different times, over different frequency bands, or using other multiple access techniques. The most challenging obstacle for STAR systems is the self-interference cancellation ratio around 90dB. Self-interference cancellation techniques can be classified into three main categories: passive suppression, analogue cancellation and digital cancellation. Passive suppression aims at maximising the isolation between the transmit and receive antennas. Analogue cancellation aims at suppressing self-interference in the RF domain by combining the received signal with an appropriately scaled and phase-shifted copy of the transmit signal in order to cancel out the self-interference. Digital cancellation aims at removing any residual interference remaining after RF cancellation by using digital cancellation techniques such as ECA (Extensive Cancellation Algorithm makes use of the least squares estimator to minimise the filter residual) or CGLS (Conjugate Gradient Least Squares, which is an alternative to the least squares estimator).

The project demonstrates narrowband self-interference cancellation by using a multi-layer cancellation scheme comprising of passive suppression, RF cancellation and digital cancellation techniques. The demonstrator comprises of a multi-layer cancellation system built around WiFi antennas which operate at the 5.8 GHz ISM frequency band. The complete experimental system design is illustrated in Figure 23.

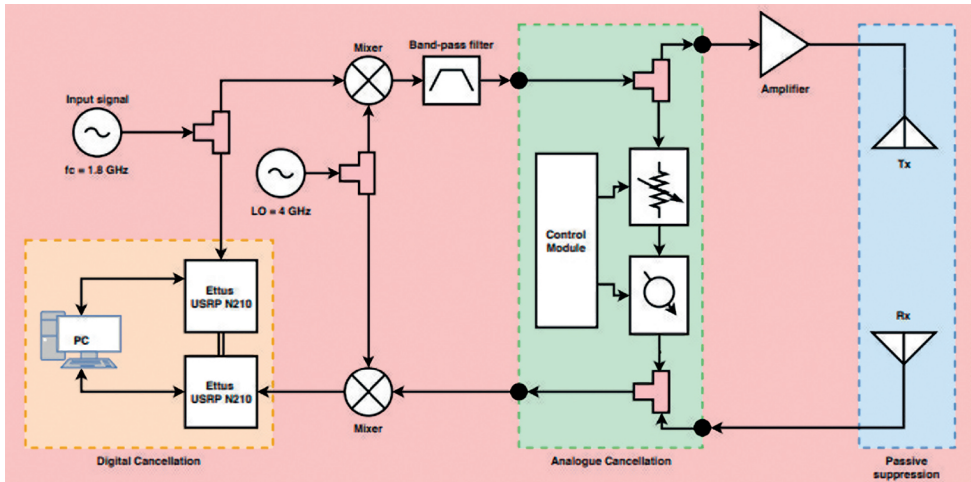

Figure 23.
Experimental system design [16]

Experiments were carried out using a 4 MHz chirp transmit signal in order to quantify the performance of analogue and digital cancellation. The transmit-receive isolation was measured both in an anechoic chamber as well as in a multipath laboratory environment, and testing was done using both a single transmit antenna and the transmit antenna array. In an anechoic chamber, the single transmit antenna produced 44dB of isolation and the antenna array produced 57.5dB of isolation. The array showed an improvement in isolation of 22.1dB, from 29.4dB isolation (single transmit antenna) to 51.5dB isolation (transmit array) in realistic multipath environment. The results of the experiments carried out are presented in Figure 24. Digital cancellation was performed using both the CGLS method (a) and ECA method (b) for comparison. The normalised received signal after passive suppression is used as the benchmark to be able to quantify the analogue and digital cancellation performance. A total of 26dB of analogue cancellation was achieved. Digital cancellation produced 16 to 20dB of cancellation without analogue cancellation preceding it. Overall, 42 to 46dB of cancellation were achieved when combining the two cancellation techniques.

As a conclusion, the developed STAR demonstrator shows the potential of these cancellation techniques for use in STAR systems.

An ultra-small antenna for UWB radars operating at frequencies from 1 to 9 GHz was also proposed, which exploits a simple electrically short dipole printed on a PCB material with an integrated differential amplifier placed directly in the centre of the dipole [17].

The Smith chart of the S_{11} parameter simulations and measurement in the single-ended configuration is shown in Figure 25. The results from all design stages show that the inputs feature high impedance with capacitive behaviour at high frequencies. That is the desired feature for the amplifier to be used with electrically short UWB antennas, where resistive loading of the antenna should be eliminated. The mismatch between the post-layout simulation and the measured data may be caused by a relatively high parasitic resistance of the microprobe contact on the input port of the chip.

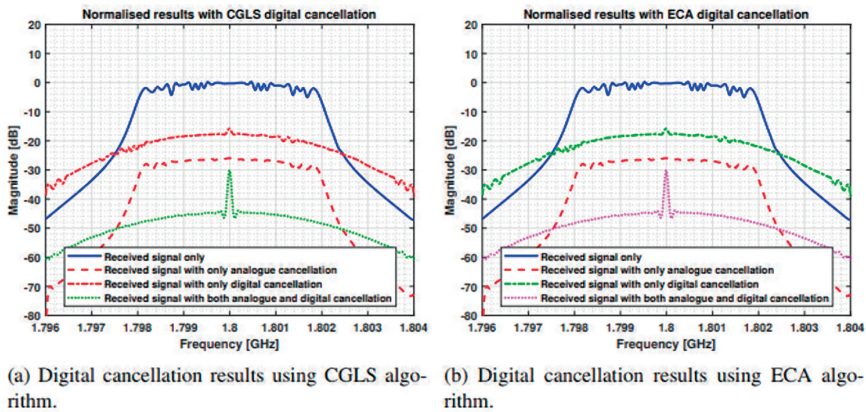

Figure 24.

Results of digital cancellation algorithms [16]

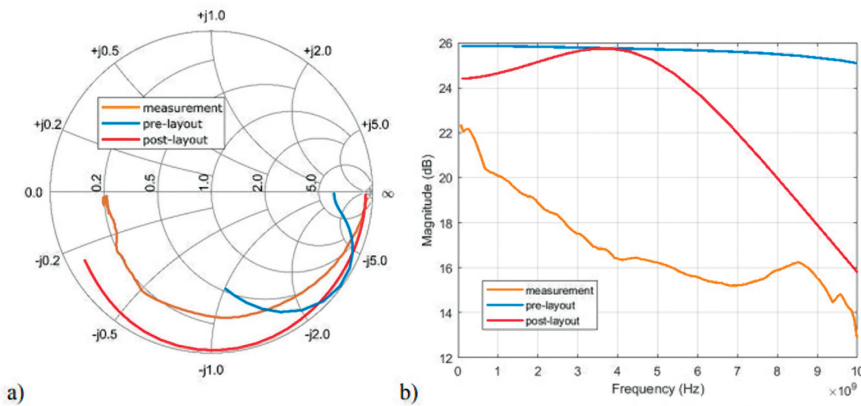

Figure 25.

Smith chart S_{11} and S_{21} of the amplifier performances [17]

The performance of the final antenna prototype was measured and compared to a professional antenna. From the results one can conclude that the antenna dimensions and weight, see Figure 25, has been successfully reduced by a factor greater than 10, while the characteristics of the antenna dropped by less than 10dB, dependent on frequency. The main advantages of the proposed antenna are small size, light weight and low production costs if high volumes are produced.

The proposed antenna is omnidirectional, which is a useful feature in short-range radar applications.

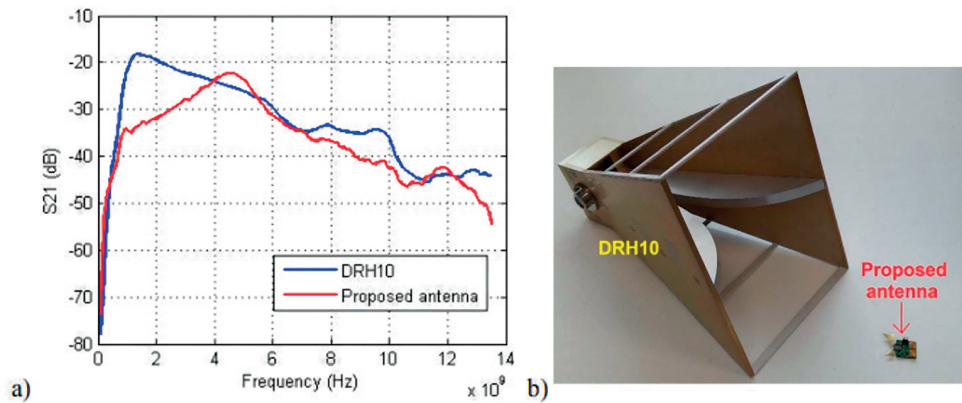

Figure 26

a) Transmission coefficient of the antenna (red) compared to the professional antenna (blue) b) comparison of dimensions of the measured antennas [17]

A methodology for image segmentation for path planning for low-THz short range radar images for automotive/autonomous platforms has been proposed [18]. The fundamental thought behind the choice of the methodology, utilising the high diffuse backscatter returns at low THz frequencies for segmentation, has been described. Operational Parameters of the prototype low-THz FMCW Radar are: Centre Frequency = 148 GHz, Bandwidth/Range Resolution = 6 GHz/2.5 cm, Antenna Beam Width = 1.5° (two-way), Power (into Antenna) = 15 mW (12 dBm), Modulation = Linear Up/Down Chirp, Chirp Duration = 1 ms. Figure 27 shows 150 GHz turntable mounted FMCW radar with fan beam antennas for real aperture scene imaging, while the right image shows a radar mounted on a vehicle alongside other experimental equipment.

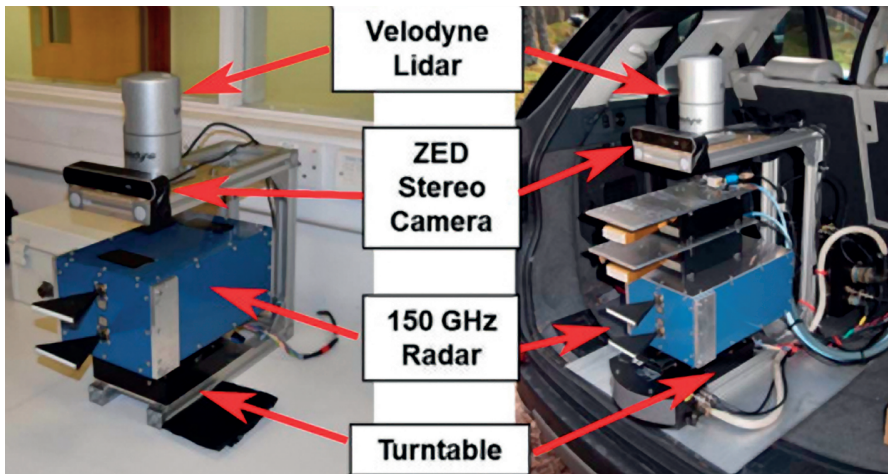

Figure 27.

The mounting structure of the 150 GHz turntable mounted FMCW radar [18]

The methodology has been tested on experimental low-THz radar imagery and shown excellent potential for image segmentation. Features in the segmented images have been discussed, such as segmented shadow regions and how they may inform path planning procedures. An example scene is shown in Figure 28, (a) showing camera and (b) low-THz radar imagery. Letters highlight image features: F–foliage, P–pedestrian, V–vehicle, O–obstruction (branch), T–track, G–gully; (water filled)-image normalised to image maxima.

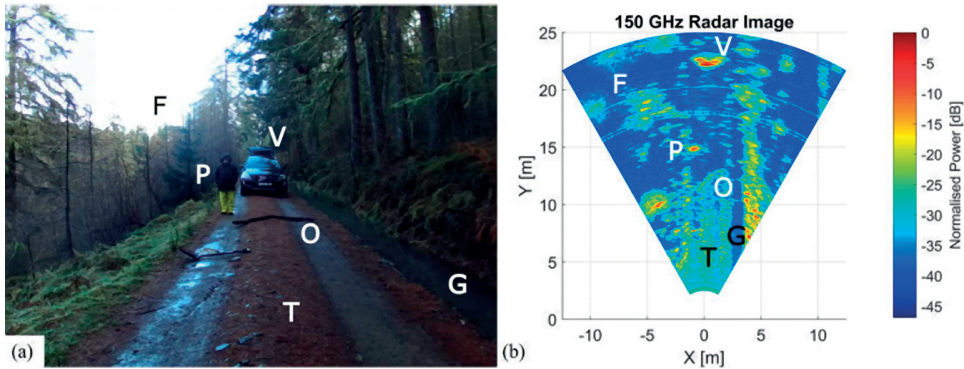

Figure 28. (a) Camera view (b) low-THz radar imagery [18]

The proposed technique combined with other complementary approaches will ultimately be used to classify road surface type from the imagery, which is planned for future study. Surface type identification from imagery will be fundamental for path planning and will also be used to inform existing vehicle technologies, such as the terrain response systems used to adapt vehicle settings when encountering different underlying surfaces.

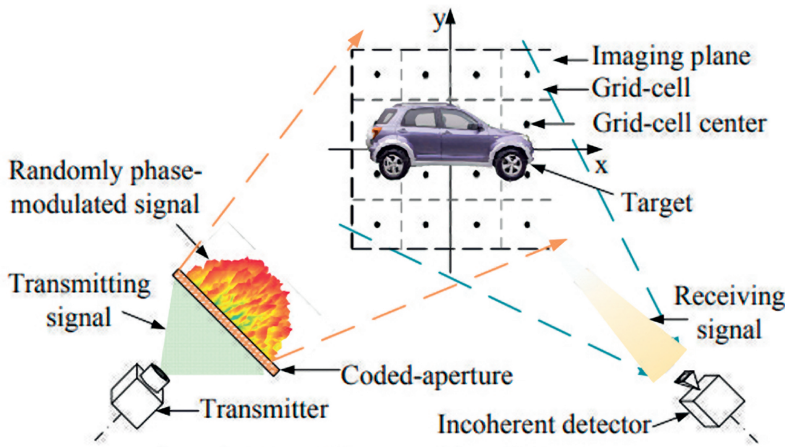

Figure 29. The architecture of the TCAI system [19]

The paper *Application of Phase Retrieval Algorithms in Terahertz Coded Aperture Imaging* demonstrates that the application of phase retrieval algorithm in the Terahertz Coded-Aperture Imaging (TCAI) system is feasible and it can obtain high quality images using only the intensity of echo signals [19]. Figure 29 shows the system architecture of the TCAI system: a transmitter, an incoherent detector, a coded-aperture antenna and a terminal control machine. The imaging plane in which the target is located is divided into several grids, and it is assumed that each strong scattering point of the target is just at the centre of the corresponding grid, which corresponds to a phase-less imaging equation.

The feasibility of adopting the phase retrieval algorithms to achieve phase-less imaging in the TCAI system is demonstrated, because the signals of the TCAI can be randomly distributed and uncorrelated in space. Figure 30 depicts the simulation results of the TCAI system based on phase retrieval algorithms: (a) The original image of target; (b) Imaging result of $N/M = 10$; (c) Imaging result of $N/M = 15$; (d) Imaging result of $N/M = 20$; (e) Imaging result of $N/M = 25$; (f) Imaging result of $N/M = 30$. The imaging quality is seriously affected by the ratio between the number of measurements and the number of grid cells.

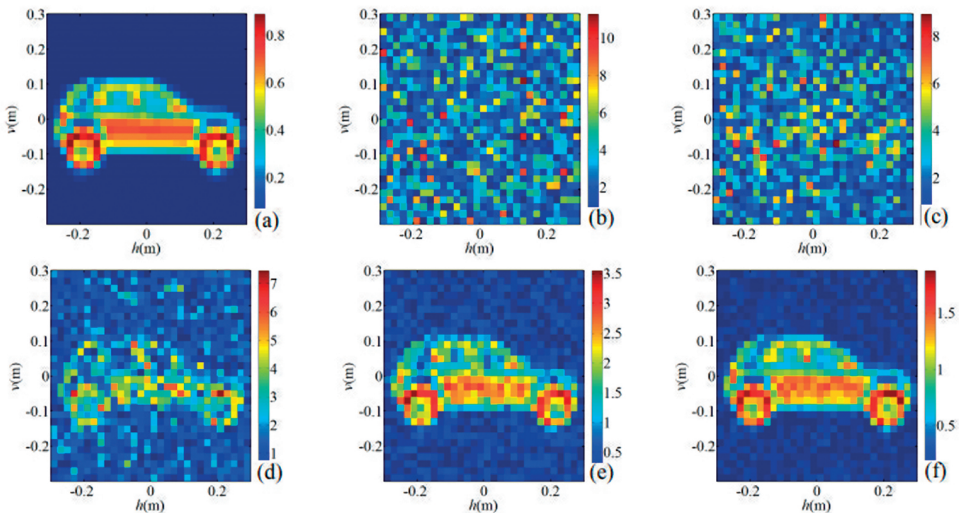

Figure 30.
Simulation results of the TCAI system based on phase retrieval algorithms [19]

The simulation results show the potential of phase retrieval algorithm, which can use a single incoherent detector to realise the phase-less imaging of the TCAI system. Phase-less imaging methods provide a solution for systems that cannot accurately measure phase during reception such as automatic drive, security check, missile terminal guidance, etc.

The paper on *Trials of a Noise-Modulated Radar Demonstrator – First Results in a Marine Environment* describes the initial results which have a noise-limited sensitivity and antenna configuration similar to small conventional marine radar [20]. The importance of being able to control the dynamic range is highlighted. In this respect, the trials have demonstrated the effectiveness of new algorithms called Band Limited Algorithm for Sidelobes Attenuation (BLASA) tailored waveforms in order to improve the useful dynamic range of the radar. The

importance of being able to handle the effects of interference due to pulse radars operating in the same band is also illustrated. An important tactical benefit of Noise Radar Technology (NRT) is the ability to deliver an assured degree of Low Probability of Intercept (LPI), Low Probability of Identification (LPID) and Low Probability of Exploitation (LPE) performance which, because of the random nature of the waveforms, cannot be circumvented by present-day and future intercept receivers.

Figure 31 shows the block diagram of the demonstrator (left) and its physical arrangement (right). The radar was operated at a duty cycle of 33% ($109\mu\text{s}$ signal repeated at 3 kHz rate) with mean power 12dBm, while the noise figure of the demonstrator was 4dB. The isolating plate improved the isolation between the transmit and receive antennas to 67dB, so the mean leakage power into the receiver is -55dBm . With a signal bandwidth of 50 MHz the time-bandwidth product of the waveform is 37dB so, with a random waveform, the range sidelobes of the direct leakage have an average value of -92dBm . The main novelty in BLASA is the ability to determine the number of lags to be suppressed after having considered the number of available unknown variables (i.e. samples) aimed at satisfying a given optimisation criterion for Tailored Noise Waveforms. A clear rationale for attenuating only a subset of the sidelobes (namely those between the mainlobe and a chosen lag) is the radar horizon, typical of marine, or coastal, radar applications.

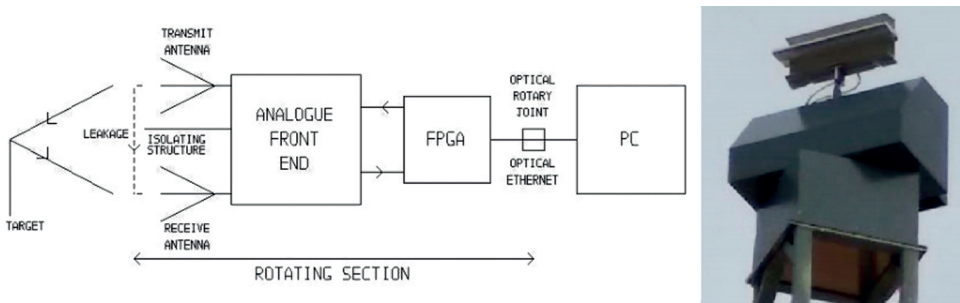

Figure 31.
Simplified Block Diagram of the Software Defined Noise Radar [20]

Figure 32 shows a comparison between PPI images obtained with LFM chirp and band limited Gaussian noise waveforms. Targets observed on both scopes are shown in red circles.

As expected, the sensitivity of Noise Radar is currently limited by the range sidelobes of the direct leakage signal which conceals some of the targets that are visible on LFM chirp PPI image. Using an LFM waveform confirmed that there was extensive interference (observed as straight lines along range direction) present in the area from other radars in the same frequency band. In the PPI image obtained using noise waveforms, bursts of interference from pulse radars are not correlating with the noise radar's noise-like transmit signals at all, hence effects of interference are mitigated on the PPI image. Deeper analyses proved that the sidelobe level with the pure noise waveform is approximately 40dB below the direct leakage, in agreement with the time-bandwidth product of 37dB. The value of the BLASA waveform supports the belief that cancellation of the direct leakage will significantly enhance the sensitivity of the PPI images obtained with a pure noise waveform.

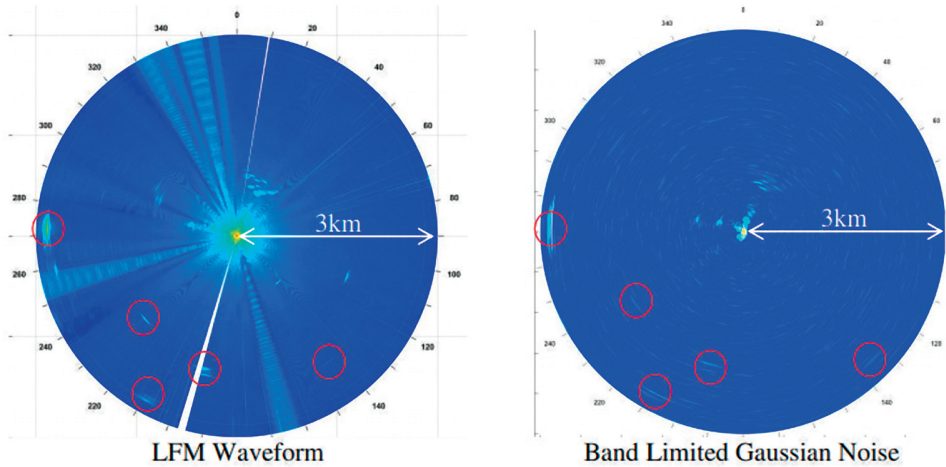

Figure 32.
PPI images obtained with LFM chirp and BLASA waveforms [20]

Authors from Vietnam proposed *A Staggered PRF Coherent Integration for Resolving Range-Doppler Ambiguity in Pulse-Doppler Radar* [21]. Two staggered Pulse Repetition Frequencies (PRF) are used to extend blind Doppler frequency, as shown in Figure 33.

The principle of the coherent processing method for staggered PRF pulse-train applies butterfly algorithm of FFT-N points. The phase/time compensation algorithm is implemented for coherent integration of non-coherent pulse-trains. As a result, the Doppler frequencies of targets are determined as observed in Figure 34.

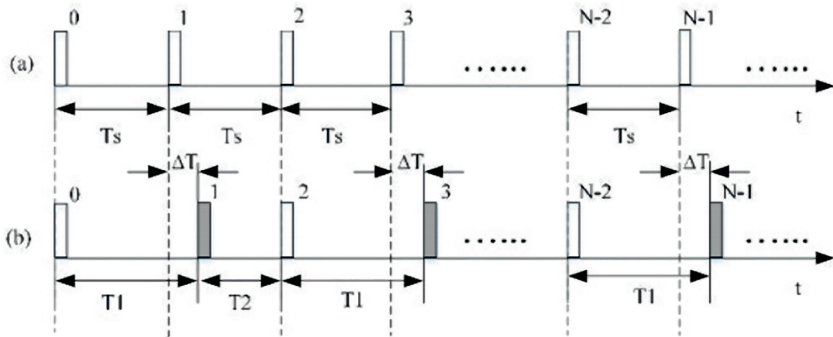

Figure 33.
Transmission of constant PRF (a) and transmission of staggered PRF (b) [21]

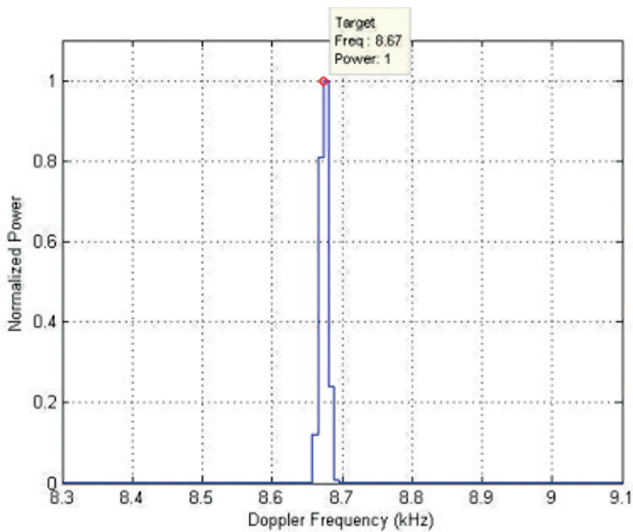

Figure 34.

Power-Doppler diagram of returned target signal (radical velocity is 1,000 m/s) [21]

Findings on automotive radar

The next paper describes *inter-radar interference analysis of fast chirp FMCW radar* and proposes a concept of scalable fast chirp FMCW radar for automotive applications [22]. The inter-radar interference of automotive FMCW radars is an emerging problem for automotive radar applications in case of dense deployment. Figure 35 shows an example of wide band interference of a fast chirp FMCW radar where TU is up chirp time duration, TD is down chirp time duration and Δf is chirp frequency bandwidth. Either narrow band interference or wide band interference occurs when beat frequency caused by interference radar is lower than LPF (Low Pass Filter) bandwidth in FMCW radar, f_{LPF} . The observation is that fast chirp FMCW radars using different chirp rates interfere with each other and the desired signal power significantly decreases after wide band interference suppression, especially when the number of interference radars is large. The desired signal power is improved by the proposed concept of scalable fast chirp FMCW radar, where chirp direction alternates according to the chirp period; the peak power of the beat signal is decreased by interference suppression when N is large since the interference suppression is equivalent to ASK (Amplitude Shift Keying) modulation for the beat frequency signal. Evaluation results validate the proposed concept and can improve the performance degradation of fast chirp FMCW radar while meeting various design requirements.

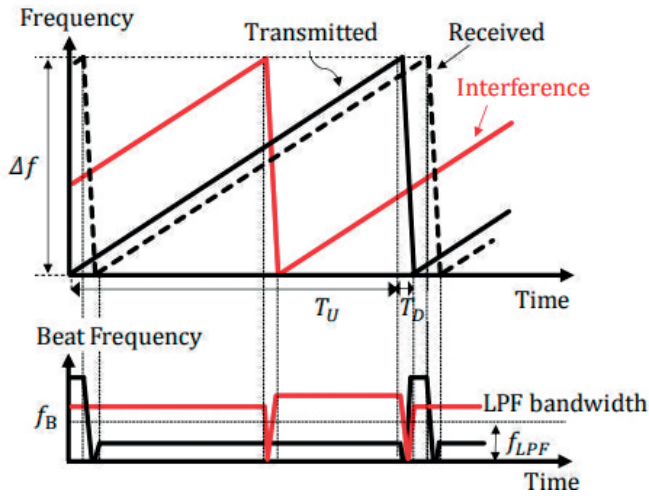

Figure 35. Wide band interference in fast chirp FMCW radar [22]

The aim of the article *Millimeter-wave Phased Antenna Array for Automotive Radar* is to consider the features of building a phased antenna array for automotive radar [23]. The proposed linear array is built on the basis of microstripe lines with the structure of the linear array consisting of 16 patches, as Figure 36 presents.

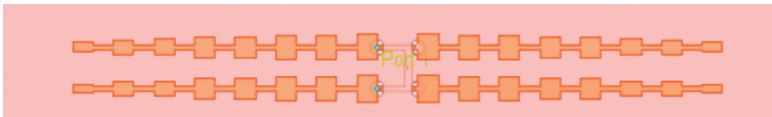

Figure 36. The model of the combined in pair of two linear arrays [23]

The structure of the entire phased antenna array, consisting of 16 sub-arrays described in Figure 36, and 2 pairs of transmitting columns is presented in Figure 37.

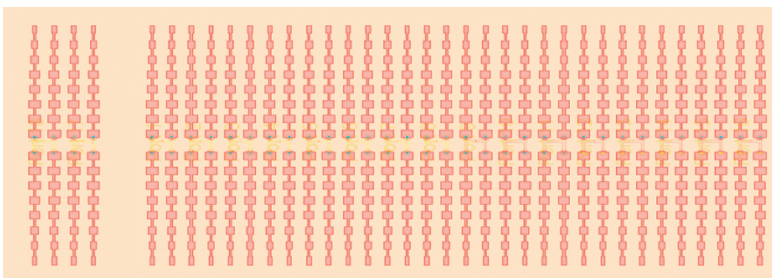

Figure 37. The phased antenna array structure of millimetre range [23]

Figure 38 shows the directivity pattern as a function of the azimuth angle α , of the phased antenna array in H-plane (azimuth) (with a uniform weight distribution of signals in columns). The phased antenna array forms a directivity pattern with -20dB and -35dB sidelobe level in E and H plane respectively, and has a high gain of 32dB .

The designed antenna has been used in the composition of automotive radar of millimetre range.

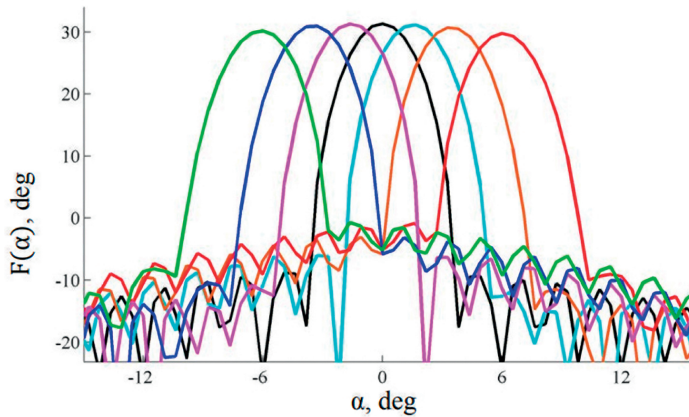

Figure 38. Measurement results of building vibration [23]

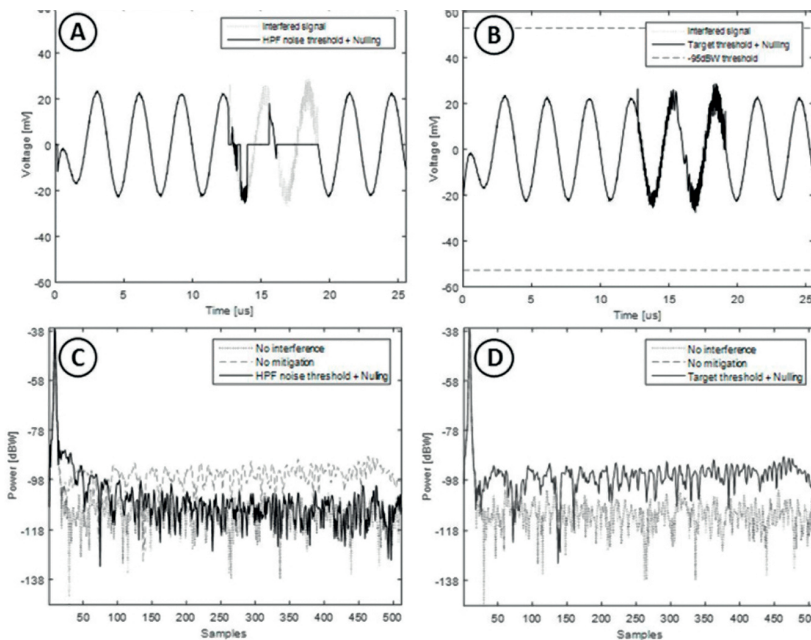

Figure 39. Comparison of the proposed and the conventional interference adaptive method [24]

Enhanced *Interference Detection Method in Automotive FMCW Radar System* has been presented in [24]. Frequency Modulated Continuous Wave (FMCW) radar to radar interference can cause severe dynamic range penalties in the radar receiver which lead to a reduction of the maximum detectable range, as well as sensitivity losses. State of the art FMCW to FMCW radar interference detection techniques are prone to miss weak interference. Though weak, this interference can still decrease sensitivity. A high pass filter can be applied before the first stage of range processing to reduce the contribution of the close and strong reflectors in the interference detection process. The situation where interference power is comparable to target power is analysed in Figure 39. Figure 39 A and B represent the timed domain interfered signal and the results of the nulling procedure. It can be observed that, in the case of the target threshold, the interference cannot be detected, and no mitigation process can be used. The result of the range profile is shown in Figure 39 D, where the noise floor after the target threshold-based detection and mitigation is equal to the one without any detection and mitigation. Figure 39 C shows, where the noise floor can be reduced, and the dynamic range restored.

The situation where interference power is larger than the target power is analysed in Figure 40. In this case, as can be seen in Figure 40 B, some interference components are above the target threshold and interference can also be detected using conventional methods. Therefore, nulling can be applied but a full dynamic range cannot be achieved (Figure 40 D). On the other hand, the mask obtained using the HPF can detect the interference pattern (Figure 40 A) and restore the noise floor (Figure 40 C). Some dynamic range losses are due to the losses in the compression gain after nulling the interfered samples.

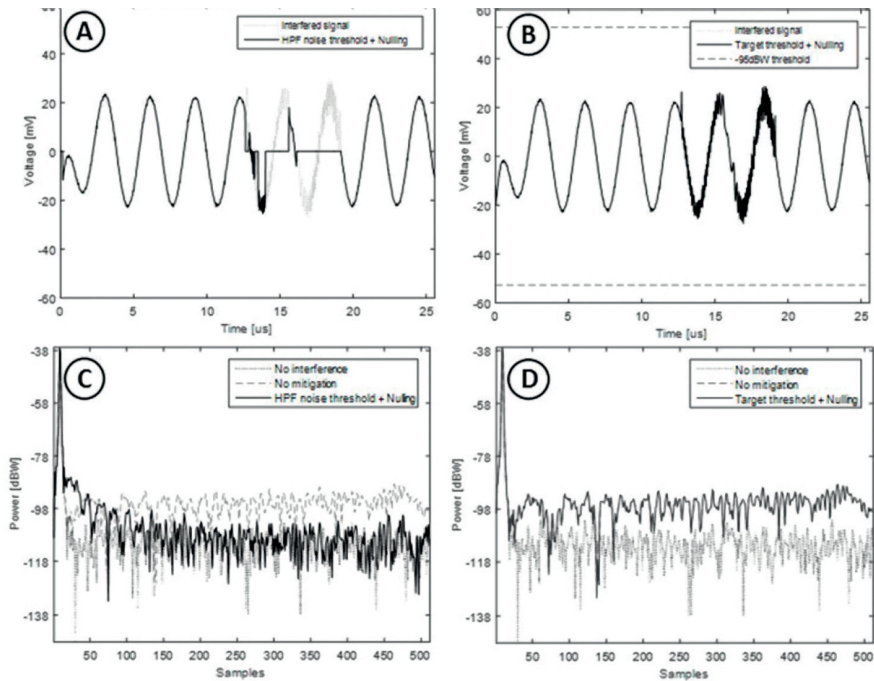

Figure 40.

Situation where interference power is comparable to target power [24]

A deep neural network can be successfully utilised for classifying several roadside objects in low THz radar imagery shown in Figure 41 [25]. The findings suggest that, by setting the right hyper-parameters and by carefully optimising the computational load and the format of the input data are the key requirements.

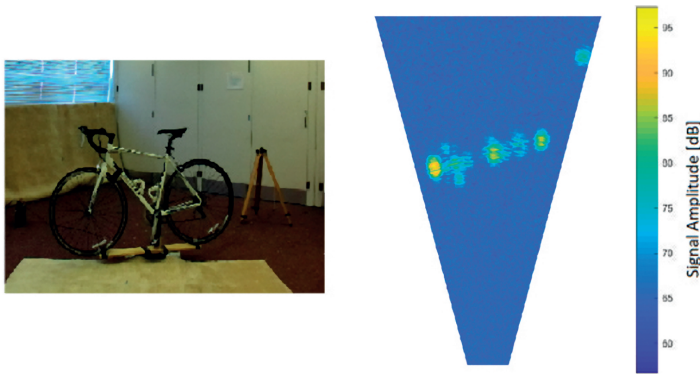

Figure 41. Optical image of a bicycle (left); corresponding radar image (right) [25]

The experiments involved reducing the image sizes and the depth of the images by converting the original RGB images with three dimensions into single dimension, grayscale images. It was found that, for this type of images, RGB images are more accurate than the grayscale ones and reduced size images with 110 x 110 pixels lessen the computational load of the model, without affecting the training and testing accuracies.

The findings, shown in Figure 42, confirm that deep neural networks are suitable approaches for low-THz imagery, due to the considerably high accuracy on testing dataset (98.78%) that was achieved throughout the project.

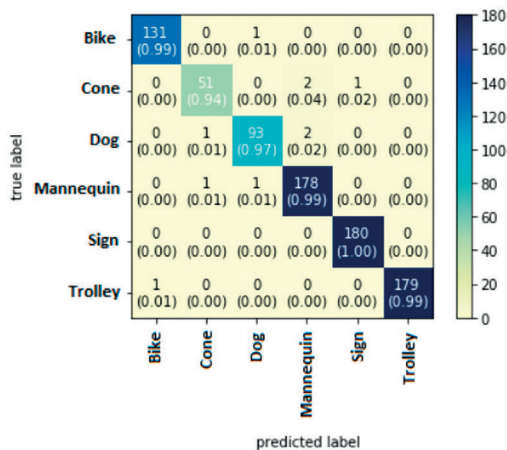

Figure 42. CNN confusion matrix [25]

Conclusion

It is vital to note that the interest in modern radar node reliable synchronisation approaches and in situ performance tests are suitable for in situ performance testing and operation in interfered or jammed environment, which is increasing. The main objective of the Electronic Protection Measures (EMP) is to eliminate or to reduce the efficiency of the interferences produced in hostile environment. The EMP performance is critical from a radar engineering and operational standpoint. It is vital that the EPM performances are considered during the lifecycle of radars, initial requirements of the acquisition/validation, modernisations throughout in-service support, in order to ensure they continue to be fit for their missions in heavily interfered environment.

Obvious and well-known advantages of passive radars, with respect to their active (i.e. based on dedicated transmitters) counterparts are the low cost, the absence of own transmitters, making them totally 'green' and installable in places where heavy active radars cannot be located and the covertness. Furthermore, numerous transmitters for telecommunications, radio navigation, and remote sensing applications are foreseen as sources of opportunity for a wide variety of short- and long-range surveillance applications. It gives a solid platform for their civilian and military applications; therefore, their applications need improved attention.

Consequently, the findings related to emerging technologies or to deep neural networks that perform object classification for self-driving vehicles using electro-optical sensors have to maximise radar performance for the harsh operational conditions.

References

- [1] "International Radar Symposium, 26–28 June 2019," Proceedings of the International Radar Symposium (IRS), 2019. Available: www.dgon-irs.org/en/home/ [Accessed Sept. 13, 2019].
- [2] "Conference Report 2019," Proceedings of the International Radar Symposium (IRS), 2019. Available: www.dgon-irs.org/en/conference/irs-history/report-2019/ [Accessed Sept. 13, 2019].
- [3] M. Weiß, S. Sandenbergh, F. Valdes, P. Müller, D. Bok, M. Kohler, D. O'Hagan, and P. Knott, "Aspects of Next Generation Sensor/Radar Networks," Fraunhofer FHR, Proceedings of the International Radar Symposium (IRS), 2019. DOI: <https://doi.org/10.23919/irs.2019.8768188>
- [4] V. Winkler and S. Lutz, "Large-Scale Passive Radar Cluster Operation," Hensoldt GmbH, Proceedings of the International Radar Symposium (IRS), 2019. DOI: <https://doi.org/10.23919/irs.2019.8768151>
- [5] K. Kulpa and M. Malanowski, "From Klein Heidelberg to Modern Multistatic Passive Radar," Warsaw University of Technology, Poland, Proceedings of the International Radar Symposium (IRS), 2019. DOI: <https://doi.org/10.23919/irs.2019.8768176>
- [6] F. Santi, F. Pieralice, D. Pastina, M. Antoniou, and M. Cherniakov, "Passive radar imagery of ship targets by using navigation satellites transmitters of opportunity," Sapienza University of Rome, Italy; University of Birmingham, U.K., Proceedings of the International Radar Symposium (IRS), 2019. DOI: <https://doi.org/10.23919/irs.2019.8768131>

- [7] I. Norheim-Næss, E. Finden and K. Strøm, "Passive Radar detection of small UAV over sea," Norwegian Defence Research Establishment, Proceedings of the International Radar Symposium (IRS), 2019. DOI: <https://doi.org/10.23919/irs.2019.8768179>
- [8] A. Strecker, "Drone-features and their corresponding consequences for the design of a radar for drone-detection, tracking and classification," Hensoldt GmbH, Proceedings of the International Radar Symposium (IRS), 2019.
- [9] F. X. Hofele, "A New Algorithm for Automatic Radar Target Classification Using Feature Extraction Having Special Regard to Drones," Hensoldt GmbH, Proceedings of the International Radar Symposium (IRS), 2019. DOI: <https://doi.org/10.23919/irs.2019.8768116>
- [10] A. Hanewinkel, "Architecture and operational results of feature based automatic radar target classification," Hensoldt GmbH, Proceedings of the International Radar Symposium (IRS), 2019. DOI: <https://doi.org/10.23919/irs.2019.8768189>
- [11] M. Schartel, R. Bahnemann, R. Burr, W. Mayer, and C. Waldschmidt, "Position Acquisition for a Multicopter-Based Synthetic Aperture Radar," Institute of Microwave Engineering, Ulm University, Germany; Autonomous Systems Lab, Zurich, Switzerland; Endress+Hauser SE+Co., Maulburg, Germany, Proceedings of the International Radar Symposium (IRS), 2019. DOI: <https://doi.org/10.23919/irs.2019.8768172>
- [12] C. Wasserzier, J. G. Worms and D. O'Hagan, "A Concept for Far Field Measurements of Large Dimension Antennas in an Open Area Test Site Performed by UAS," Fraunhofer FHR, Proceedings of the International Radar Symposium (IRS), 2019. DOI: <https://doi.org/10.23919/irs.2019.8768157>
- [13] R. Krebs, M. Andres and M. Bockmair, "A Modular and Scalable Architecture for RF Payloads on MALE RPAS," European Defence Agency; Hensoldt GmbH, Proceedings of the International Radar Symposium (IRS), 2019. DOI: <https://doi.org/10.23919/irs.2019.8768166>
- [14] M. Jahangir and C. J. Baker, "CLASS U-space drone test flight results for non-cooperative surveillance using an L-band 3-D staring radar," Aveillant, A Thales Company; University of Birmingham, U.K., Proceedings of the International Radar Symposium (IRS), 2019. DOI: <https://doi.org/10.23919/irs.2019.8768155>
- [15] S. Maresca, G. Serafino, F. Scotti, F. Amato, L. Lembo, A. Bogoni, and P. Ghelfi, "Photonics for Coherent MIMO Radar: An Experimental Multi-Target Surveillance Scenario," TeCIP Institute, Pisa; PNTLab, Pisa; Vallauri Institute, Livorno, Italy, Proceedings of the International Radar Symposium (IRS), 2019. DOI: <https://doi.org/10.23919/irs.2019.8768096>
- [16] A. Parker, F. Schonken, and D. O'Hagan, "Self-interference Cancellation for Simultaneous Transmit and Receive Applications," University of Cape Town, Cape Town, South Africa, Fraunhofer FHR, Proceedings of the International Radar Symposium (IRS), 2019. DOI: <https://doi.org/10.23919/irs.2019.8768163>
- [17] M. Pecovsky, M. Sokol, S. Slovak, and P. Galajda, "Miniaturized UWB Radar Receiving Antenna with Integrated Cherry-Hooper Amplifier," Technical University of Košice, Košice, Slovakia, Proceedings of the International Radar Symposium (IRS), 2019. DOI: <https://doi.org/10.23919/irs.2019.8768098>
- [18] L. Daniel, D. Phippen, E. Hoare, M. Cherniakov, and M. Gashinova, "Image Segmentation in Real Aperture Low-THz Radar Images," University of Birmingham Birmingham, U.K., Proceedings of the International Radar Symposium (IRS), 2019. DOI: <https://doi.org/10.23919/irs.2019.8768106>

- [19] L. Peng, C. Luo, H. Wang, Y. Cheng, Q. Yang, and K. Liu, "Application of Phase Retrieval Algorithms in Terahertz Coded Aperture Imaging," National University of Defense Technology, Changsha, China, Proceedings of the International Radar Symposium (IRS), 2019. DOI: <https://doi.org/10.23919/irs.2019.8768124>
- [20] K. Savci, A. G. Stove, A. Y. Erdogan, G. Galati, K. A. Lukin, G. Pavan and C. Wasserzler, "Trials of a Noise-Modulated Radar Demonstrator – First Results in a Marine Environment," Turkish Naval Research Center Command, Pendik/Istanbul, Turkey; Vergata University, Rome, Italy; IRE NASU, Kharkov, Ukraine; University of Birmingham, Birmingham, UK; Fraunhofer FHR, Proceedings of the International Radar Symposium (IRS), 2019. DOI: <https://doi.org/10.23919/irs.2019.8768194>
- [21] V. V. Tien, T. V. Hop, N. Nhu, D. X. Hoang and N. V. Loi, "A Staggered PRF Coherent Integration for Resolving Range-Doppler Ambiguity in Pulse-Doppler Radar," Radar Center, Viettel High Technology Industries Corporation Hanoi, Vietnam, Proceedings of the International Radar Symposium (IRS), 2019. DOI: <https://doi.org/10.23919/IRS.2019.8768110>
- [22] M. Umehira, Y. Makino, T. Okuda, X. Wang, S. Takeda, and H. Kuroda, "Inter-Radar Interference Analysis and Concept of Scalable Fast Chirp FMCW Radar for Automotive Applications," Ibaraki University & Hitachi Automotive Systems, Japan, Proceedings of the International Radar Symposium (IRS), 2019. DOI: <https://doi.org/10.23919/irs.2019.8768092>
- [23] S. A. Shabalín, A. V. Myakinkov, A. A. Kuzin and A. G. Ryndyk, "Millimeter-wave Phased Antenna Array for Automotive Radar," State Technical University of Nizhny Novgorod, Russia, Proceedings of the International Radar Symposium (IRS), 2019. DOI: <https://doi.org/10.23919/irs.2019.8768182>
- [24] F. Laghezza, F. Jansen and J. Overvest, "Enhanced Interference Detection Method in Automotive FMCW Radar Systems," NXP Semiconductors, Eindhoven, The Netherlands, Proceedings of the International Radar Symposium (IRS), 2019. DOI: <https://doi.org/10.23919/irs.2019.8767459>
- [25] A. Stroescu, M. Cherniakov, and M. Gashinova, "Classification of High Resolution Automotive Radar Imagery for Autonomous Driving Based on Deep Neural Networks," University of Birmingham, U.K., Proceedings of the International Radar Symposium (IRS), 2019. DOI: <https://doi.org/10.23919/irs.2019.8768156>

ÁTTEKINTÉS A 2019-ES NEMZETKÖZI RADAR SZIMPÓZIUM LEGJOBB CIKKEIRŐL, ULM, NÉMETORSZÁG

Napjainkban az interferenciaszűrés vagy -csökkentés fontos szerepet játszik a fejlett radartechnológia hatékony használatában. A cikk azokra a szimpóziumi előadásokra fókuszál, amelyek kapcsolatosak a radarrendszerek elektromágneses spektrumban való üzemelés (EMSO) problematikájával. A Magyar Honvédség korszerűsítése, a Zrínyi 2026 sikere, alapvetően az új technológiák megértésén és professzionális élettartamra szóló kiszolgálásán múlik. Polgári alkalmazásokban az autókban üzemelő radarok egymás zavarásának problematikája olyan új kihívás, amely elterjedésükkel tovább nő. Következésképpen kiemelten fontos feladat összegyűjteni, értékelni

és átültetni a gyakorlatba az új technológiákkal kapcsolatos fejlett kutatási megállapításokat és fogalmakat. Megállapítható, hogy olyan folyamatosan jelen lévő mérnöki/tudományos elvárásokat kell alkalmazni, amelyek nyomon követik és maximalizálják a radar teljesítményét, és támogatják a biztonsági elvárásokat, EMSO-körülmények közötti üzemeltetését. A cikkben a radarokkal kapcsolatos legfrissebb eredményeket foglaljuk össze, figyelembe véve a hazai elvárásokat.

Kulcsszavak: rádiólokátor, aktív zavarás/zavarvédelem, Passzív Radar (PR), bi- és multistatikus radarrendszerek, kognitív rádiólokátor

Balajti István
külsős tanár
Nemzeti Közszolgálati Egyetem
balajti.istvan@uni-nke.hu
<https://orcid.org/0000-0003-3566-2904>

István Balajti
visiting lecturer
Doctoral School of Military Sciences
National University of Public Service
balajti.istvan@uni-nke.hu
<https://orcid.org/0000-0003-3566-2904>



VÁKÁT OLDAL